

Cod. 21

**PUNZONI DIN 9861 FORMA D IN ACCIAIO CROMO
PER STAMPI**

Materiale: acciaio UNI X205Cr12 n. 1.2080.
Trattamento termico: tempra e rinvenimento.
Durezza gambo: 60 ÷ 64 HRC.
Durezza testa: 40 ÷ 50 HRC.
Esecuzione: rettifica e lappatura.
Esempio di ordinazione: D * L

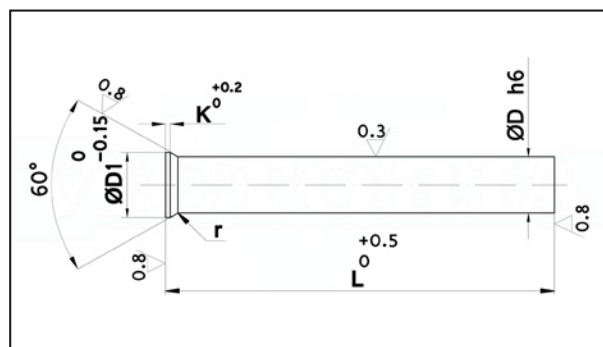

4

D	D1	L K	71	80	100	120
0.6	1.1	0.2	•	•	•	•
0.7	1.3	0.2	•	•	•	•
0.8	1.4	0.4	•	•	•	•
0.9	1.6	0.4	•	•	•	•
1 - 1.1	1.8	0.5	•	•	•	•
1.2 - 1.3	2	0.5	•	•	•	•
1.4 - 1.5	2.2	0.5	•	•	•	•
1.6 - 1.7	2.5	0.5	•	•	•	•
1.8 - 1.9	2.8	0.5	•	•	•	•
2	3	0.5	•	•	•	•
2.1 - 2.2	3.2	0.5	•	•	•	•
2.3 - 2.5	3.5	0.5	•	•	•	•
2.6 - 2.9	4	0.5	•	•	•	•
3	4.5	0.5	•	•	•	•
3.1 - 3.4	4.5	0.5	•	•	•	•
3.5	5	0.5	•	•	•	•
3.6 - 3.9	5	0.5	•	•	•	•
4	5.5	0.5	•	•	•	•
4.1 - 4.4	5.5	0.5	•	•	•	•
4.5	6	0.5	•	•	•	•
4.6 - 4.9	6	0.5	•	•	•	•
5	6.5	0.5	•	•	•	•
5.1 - 5.4	6.5	0.5	•	•	•	•
5.5	7	0.5	•	•	•	•
5.6 - 5.9	7	0.5	•	•	•	•
6	8	0.5	•	•	•	•
6.1 - 6.4	8	0.5	•	•	•	•
6.5	9	1	•	•	•	•
6.6 - 6.9	9	1	•	•	•	•
7	9	1	•	•	•	•
7.1 - 7.4	9	1	•	•	•	•
7.5	10	1	•	•	•	•
7.6 - 7.9	10	1	•	•	•	•
8	10	1	•	•	•	•
8.1 - 8.4	10	1	•	•	•	•
8.5	11	1	•	•	•	•
8.6 - 8.9	11	1	•	•	•	•
9	11	1	•	•	•	•
9.1 - 9.4	11	1	•	•	•	•
9.5	12	1	•	•	•	•
9.6 - 9.9	12	1	•	•	•	•
10	12	1	•	•	•	•
10.1 - 10.4	12	1	•	•	•	•
10.5 - 11.4	13	1	•	•	•	•
11.5 - 12.4	14	1	•	•	•	•
12.5 - 13.4	15	1	•	•	•	•
13.5 - 14.4	16	1.5	•	•	•	•
14.5 - 15	17	1.5	•	•	•	•
15.1 - 16	18	1.5	•	•	•	•
16.1 - 17	19	1.5	•	•	•	•
17.1 - 18	20	1.5	•	•	•	•
18.1 - 19	21	1.5	•	•	•	•
19.1 - 20	22	1.5	•	•	•	•