

Cod. 400N4

COLONNE CON ATTACCO CONICO PER STAMPI, RONDELLE CON VITE

Materiale: acciaio UNI 35 MnPb10.

Esecuzione: tornitura.

A corredo vite per fissaggio colonna.

Esempio di ordinazione: D

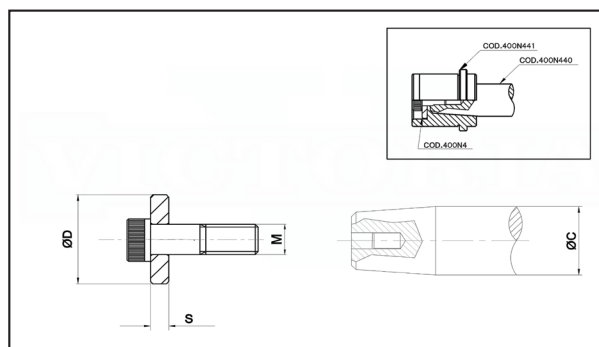

D	S	M	Per Ø C	Prezzo
22	4	M6	19 / 20	a rich.
25	5	M8	24 / 25	a rich.
32	5	M8	30 / 32	a rich.
40	5	M8	38 / 40	a rich.
50	5	M10	48 / 50	a rich.
60	5	M12	63	a rich.

Cod. 400N409

BUSSOLE LISCE PER GABBIE A SFERE-RULLI PER STAMPI

Materiale: acciaio da cementazione.

Trattamento termico: cementate e temprate.

Durezza: 62 ÷ 64 HRC.

Esecuzione: rettifica e lappatura.

Note: la gabbia non è compresa.

Esempio di ordinazione: D * L

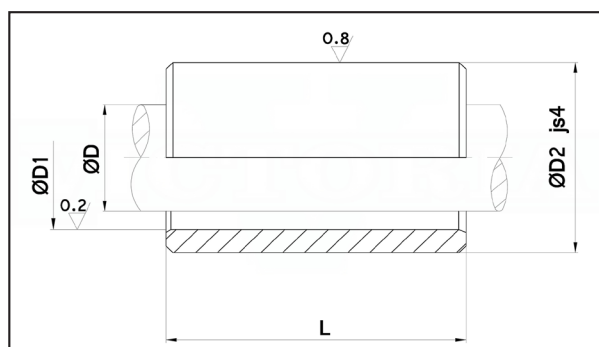

D	D1	D2	L	23	30	37	47	60	77	95	120
10	14	22		a rich.	a rich.	a rich.					
12	16	22		a rich.	a rich.	a rich.					
15	21	28		a rich.	a rich.	a rich.	a rich.	a rich.			
16	22	28		a rich.	a rich.	a rich.	a rich.	a rich.			
19	25	32		a rich.	a rich.	a rich.	a rich.	a rich.	a rich.		
20	26	32		a rich.	a rich.	a rich.	a rich.	a rich.	a rich.		
24	30	40		a rich.	a rich.	a rich.	a rich.	a rich.	a rich.		
25	31	40		a rich.	a rich.	a rich.	a rich.	a rich.	a rich.		
30	38	48			a rich.	a rich.	a rich.	a rich.	a rich.	a rich.	
32	40	48			a rich.	a rich.	a rich.	a rich.	a rich.	a rich.	
38	46	58			a rich.	a rich.	a rich.	a rich.	a rich.	a rich.	a rich.
40	48	58			a rich.	a rich.	a rich.	a rich.	a rich.	a rich.	a rich.
48	56	70				a rich.	a rich.	a rich.	a rich.	a rich.	a rich.
50	58	70				a rich.	a rich.	a rich.	a rich.	a rich.	a rich.
63	71	85						a rich.	a rich.	a rich.	a rich.
80	92	105									a rich.