

Cod. 51SH

COLONNE A DUE DIAMETRI SPALLATE

SERIE H PER STAMPI

Materiale: acciaio UNI 16CrNi4.

Trattamento termico: cementazione e tempra.

Durezza: 60 ÷ 62 HRC.

Esecuzione: rettifica e lappatura.

Esempio di ordinazione: D * L * L1

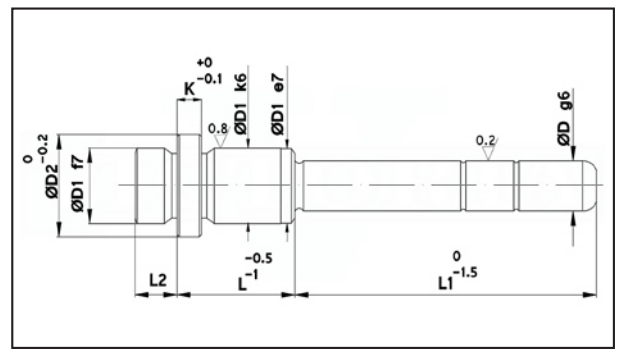

3

| D | L | D1 | D2 | K | L1 L2 | 30 | 35 | 45 | 50 | 55 | 65 | 70 | 75 | 85 | 90 | 95 | 105 | 110 | 115 |
|---------|-----|----|----|----|----------|----|----|----|----|----|----|----|----|----|----|----|-----|-----|-----|
| 14 - 15 | 22 | 20 | 25 | 6 | 9 | • | | | • | | | • | | | • | | | • | |
| 14 - 15 | 27 | 20 | 25 | 6 | 9 | • | | • | | | • | | | • | | | • | | |
| 14 - 15 | 36 | 20 | 25 | 6 | 9 | | • | | | • | | | • | | | • | | | |
| 14 - 15 | 46 | 20 | 25 | 6 | 9 | | • | • | | | • | | | • | | | • | | |
| 14 - 15 | 56 | 20 | 25 | 6 | 9 | | • | | | • | | | • | | | • | | | |
| 14 - 15 | 66 | 20 | 25 | 6 | 9 | | | | | • | • | | | | | • | | | |
| 14 - 15 | 76 | 20 | 25 | 6 | 9 | | | | | • | | | | | | • | | | |
| 18 - 20 | 22 | 26 | 31 | 6 | 9 | | • | • | | | • | | | • | | | | | • |
| 18 - 20 | 27 | 26 | 31 | 6 | 9 | | • | • | | | • | | | • | | | • | | |
| 18 - 20 | 36 | 26 | 31 | 6 | 9 | | • | | | • | | | • | | | • | | | • |
| 18 - 20 | 46 | 26 | 31 | 6 | 9 | | • | • | | | • | | | • | | | • | | |
| 18 - 20 | 56 | 26 | 31 | 6 | 9 | | • | | | • | | | • | | | • | | | |
| 18 - 20 | 66 | 26 | 31 | 6 | 9 | | • | | | • | | | • | | | • | | | |
| 18 - 20 | 76 | 26 | 31 | 6 | 9 | | | | | • | | | • | | | • | | | |
| 18 - 20 | 86 | 26 | 31 | 6 | 9 | | | | | • | | | • | | | • | | | |
| 18 - 20 | 96 | 26 | 31 | 6 | 9 | | | | | • | | | • | | | • | | | |
| 22 - 24 | 22 | 30 | 35 | 6 | 9 | | • | | | • | | | • | | | | • | | |
| 22 - 24 | 27 | 30 | 35 | 6 | 9 | | • | • | | | • | | | • | | | • | | |
| 22 - 24 | 36 | 30 | 35 | 6 | 9 | | • | | | • | | | • | | | • | | | • |
| 22 - 24 | 46 | 30 | 35 | 6 | 9 | | • | • | | | • | | | • | | | • | | |
| 22 - 24 | 56 | 30 | 35 | 6 | 9 | | • | | | • | | | • | | | • | | | • |
| 22 - 24 | 66 | 30 | 35 | 6 | 9 | | • | | | • | | | • | | | • | | | • |
| 22 - 24 | 76 | 30 | 35 | 6 | 9 | | | | | • | | | • | | | • | | | • |
| 22 - 24 | 86 | 30 | 35 | 6 | 9 | | | | | • | | | • | | | • | | | • |
| 22 - 24 | 96 | 30 | 35 | 6 | 9 | | | | | • | | | • | | | • | | | • |
| 22 - 24 | 116 | 30 | 35 | 6 | 9 | | | | | • | | | • | | | • | | | • |
| 30 - 32 | 27 | 42 | 47 | 6 | 9 | | | • | | | • | | | | | | • | | |
| 30 - 32 | 36 | 42 | 47 | 6 | 9 | | | | | • | | | • | | | • | | | • |
| 30 - 32 | 46 | 42 | 47 | 6 | 9 | | | • | | | • | | | • | | | • | | • |
| 30 - 32 | 56 | 42 | 47 | 6 | 9 | | | | | • | | | • | | | • | | | • |
| 30 - 32 | 66 | 42 | 47 | 6 | 9 | | | | | • | | | • | | | • | | | • |
| 30 - 32 | 76 | 42 | 47 | 6 | 9 | | | | | • | | | • | | | • | | | • |
| 30 - 32 | 86 | 42 | 47 | 6 | 9 | | | | | • | | | • | | | • | | | • |
| 30 - 32 | 96 | 42 | 47 | 6 | 9 | | | | | • | | | • | | | • | | | • |
| 30 - 32 | 116 | 42 | 47 | 6 | 9 | | | | | • | | | • | | | • | | | • |
| 30 - 32 | 136 | 42 | 47 | 6 | 9 | | | | | | | | • | | | • | | | • |
| 30 - 32 | 156 | 42 | 47 | 6 | 9 | | | | | | | | • | | | • | | | • |
| 40 - 42 | 56 | 54 | 60 | 10 | 12 | | | | | | | | • | | | | | | • |
| 40 - 42 | 66 | 54 | 60 | 10 | 12 | | | | | | | | • | | | | | | • |
| 40 - 42 | 76 | 54 | 60 | 10 | 12 | | | | | | | | • | | | | | | • |
| 40 - 42 | 86 | 54 | 60 | 10 | 12 | | | | | | | | • | | | | | | • |
| 40 - 42 | 96 | 54 | 60 | 10 | 12 | | | | | | | | • | | | | | | • |
| 40 - 42 | 116 | 54 | 60 | 10 | 12 | | | | | | | | | | | • | | | • |
| 40 - 42 | 136 | 54 | 60 | 10 | 12 | | | | | | | | | | | • | | | • |
| 40 - 42 | 156 | 54 | 60 | 10 | 12 | | | | | | | | | | | | | | • |
| 40 - 42 | 196 | 54 | 60 | 10 | 12 | | | | | | | | | | | | | | • |

