

Cod. 527

INSERTI FILETTATI PER LEGATURA ESTRAZIONE PER STAMPI

Materiale: acciaio da cementazione.
Esempio di ordinazione: M * passo * L

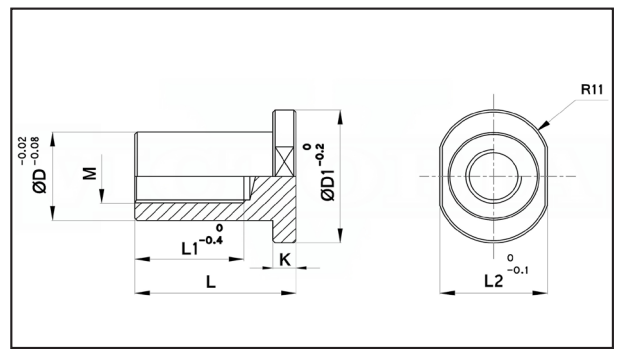

M	passo	D	D1	K	L1	L L2	42	47	52	61	66	71	76	85	95
M10	1.5	30	46	6	24	34	16,02	16,15	18,00	18,14					
M12	1.75	30	46	6	24	34	18,00	16,15	17,91	18,14					
M16	1.5	30	46	6	24	34	16,02	16,15	17,91	18,14					
M16	2	30	46	6	24	34	16,52	16,15	17,91	18,14					
M18	1.5	30	46	6	26	34	16,02	16,15	17,91	18,14					
M20	1.5	40	56	6	28	46	21,54	22,54	25,17	25,51	27,33	29,15	30,96	33,75	34,94
M20	2.5	40	56	6	28	46	21,54	22,54	25,17	25,51	27,33	29,15	30,96	33,75	34,94
M22	1.5	40	56	6	28	46	21,54	22,54	25,17	25,51	27,33	29,15	30,96	33,75	34,94
M24	1.5	40	56	6	28	46	21,54	22,54	25,17	25,51	27,33	29,15	30,96	33,75	34,94
M24	3	40	56	6	28	46	21,54	22,54	25,17	25,51	27,33	29,15	30,96	33,75	34,94

Cod. 527T

TRASCINATORI PER ESTRAZIONE TERZA PIASTRA PER STAMPI

Materiale: bussola e vite in AVP brunito.
Sostegno in nylon.
Esempio di ordinazione: D

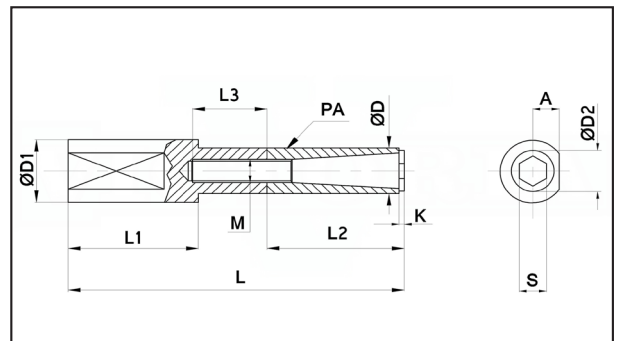

D	A	D1	D2	K	L	L1	L2	L3	M	S	Prezzo
16	8	18	13	4	72	23	25	14	M8	6	°44,89